

Insulated Sectional Doors

Thermal & Acoustic performance overhead doors

Sectional Doors

Glazed Sectional Doors



made to measure

Retail, Industrial & Commercial Sectional Overhead Doors

Welcome to Ascot Doors Limited, supplier and installer of individually made-to-measure high performance sectional overhead doors.

Made to measure

Ascot Doors offer the complete service from design, manufacture & installation to on-going service & emergency repairs.

Unrivalled aesthetics and performance have become the hallmark of Ascot's insulated sectional doors in all applications from retail & warehousing to industrial units, factories and emergency services.

Based in Lancashire, UK, Ascot supplies it's made to measure sectional doors in it's own purpose built factory using the

latest production equipment under BS ISO9001 quality assurance.

Installation teams undergo rigorous training to ensure that doors are installed in accordance with LPS1197 where appropriate, and in all cases, in the most effective and safest manner possible.

Recognised internationally for high levels of quality and safety, Ascot produces doors for UK, and overseas customers.

For all other ascot products, please refer to specific brochures.



doors fitted with vision panels



workshops
warehouses
local authorities
public buildings
utilities & factories
distribution centres
hospitals & museums
retail & shopping centres
emergency vehicle stations

Sectional overhead doors	1
Construction	1-2
Performance & modes of operation	2
Standard & contour lift track	3
High lift tack	4
Vertical lift arrangement	5
Low headroom track	6
Options & operation	7
Standard controls & electrical options	8
Service & repair	9



ISO 9001 / ISO 18001



Certificate No. 131/b
Certificate No. 131/d



Sectional Overhead Doors

Ascot's overhead sectional doors combine strength and durability with cost effectiveness.

Highly versatile and cost effective, Ascot overhead sectional doors are individually designed and manufactured to suit the specific opening and gives guaranteed high thermal and acoustic performance, compared with traditional

roller shutters. Our range of sectional doors have been designed to meet and comply with the requirements of Product Standard BS EN 13241-1:2003 Industrial, commercial and garage doors & gates.

Our range of Overhead Sectional Doors doors have been designed to comply with the mechanical requirements BS EN 12605 and BS EN 12567-1:2000 for thermal resistance and BS EN 12424 for resistance to wind loads. Insulation is afforded to the whole door area – even at joints. Panels can be prefinished in an extensive range of colours and materials. Doors accidentally damaged can be easily repaired using replacement materials and components.

Fixing arrangements

Approved installation teams install Ascot sectional doors to a variety of buildings and construction materials where thermal and sound proofing are a benefit. Doors are installed to most types of wall or openings using a combination of fixings which are calculated for every location and torques specified for individual bolt-sets within our fixing instructions. Recommended bolt sizes for fixing the door to the opening structure are calculated.

Construction

The use of quality materials and precise manufacturing controls ensure long service life in normal industrial and commercial applications. All Ascot Insulated Door Panels conform to the Building Regulations requirements for Industrial Doors.

Solid Panels

The high performance door panels are constructed from 40 mm thick galvanised steel sheets bonded together with high density CFC free polyurethane foam with a thermal break at each joint. Vision panels can be fitted into the panel sections.

Fully glazed doors

Ascot offers a range of fully or partially glazed doors manufactured from aluminium sections with a variety of glazing options.

Vertical and horizontal tracks

Hinges, brackets, side capping and hardware are galvanised with the assembled door running on adjustable galvanised roller carriers bolted to each individual panel. The door is perfectly balanced by means of helical wound counter-balanced springs at high level, mounted on galvanised steel plates and quality bearings to give smooth and quiet operation.



Max standard size 7000 x 6000
other sizes available on request



Complete door assembly



Fully glazed

Safety

Cable break devices are fitted as standard to prevent the uncontrolled dropping of the door.

Seals

Flexible rubber seals are fitted to all four sides of the door. The top seal compresses against the lintol; the bottom seal has three points of contact with the threshold for good protection against the weather. We recommend this threshold is finished with small incline away from the opening.

Finishes and colours

The internal finish of the door is white (9010) polyester coated Stucco embossed, the external face is available in a wide range of finishes including polyester, plastisol and a factory applied paint. For our current range of standard colours please see the Ascot website www.ascotdoors.co.uk.

Performance

Sound reduction

The 40 mm insulated door panel gives a weighted acoustic sound reduction of 25 db.

Thermal performance

Where heat loss is a primary concern an insulated sectional door is the obvious choice. Ascot sectional door panels provide high levels of insulation, the foam core between the inner and outer steel sheets of the door panel creates an effective thermal break, thus preventing transmission of heat or cold. The following tables provides thermal values for door panel types.

Thermal U values

Individual solid panels	0.51W/m ² k
-------------------------	------------------------

Full solid	0.9W/m ² k
------------	-----------------------



Seal



RAL or BS colours

Modes of operation

Manual operation is either push-up (up to 3000 x 3000 mm) or hand chain. Electrically operated doors is by a high quality three phase or single phase motor with starter and gearbox, incorporating digital limits. All control panels are low voltage and have open, close and emergency stop buttons as standard along with self diagnostics and service reminder. Emergency manual over-ride is provided as standard to allow operation of the door in case of power failure.

CE designed conforms to 13241-1

Standard & contour lift track systems

Standard track and contour lift track arrangements are generally used in lower roofed buildings that are required to follow the slope of building structure. These are a common type of installation on most industrial buildings. Note, the structure must be capable of carrying a door load of 25 kg/m².

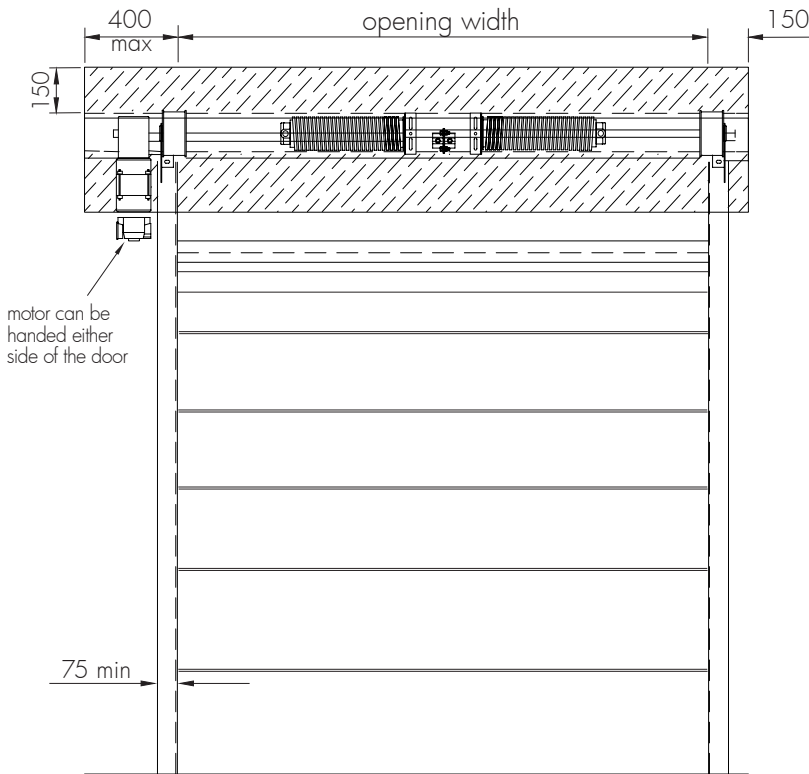

elevation from inside

Track arrangement	max width	max height	Max ² m
-------------------	-----------	------------	--------------------

Standard lift	7000	6000	36
---------------	------	------	----

Side room requirements	mm	mm
------------------------	----	----

Push-up	150	150
---------	-----	-----

Chain hoist doors	350	150
-------------------	-----	-----

Electrically operated doors	400	150
-----------------------------	-----	-----

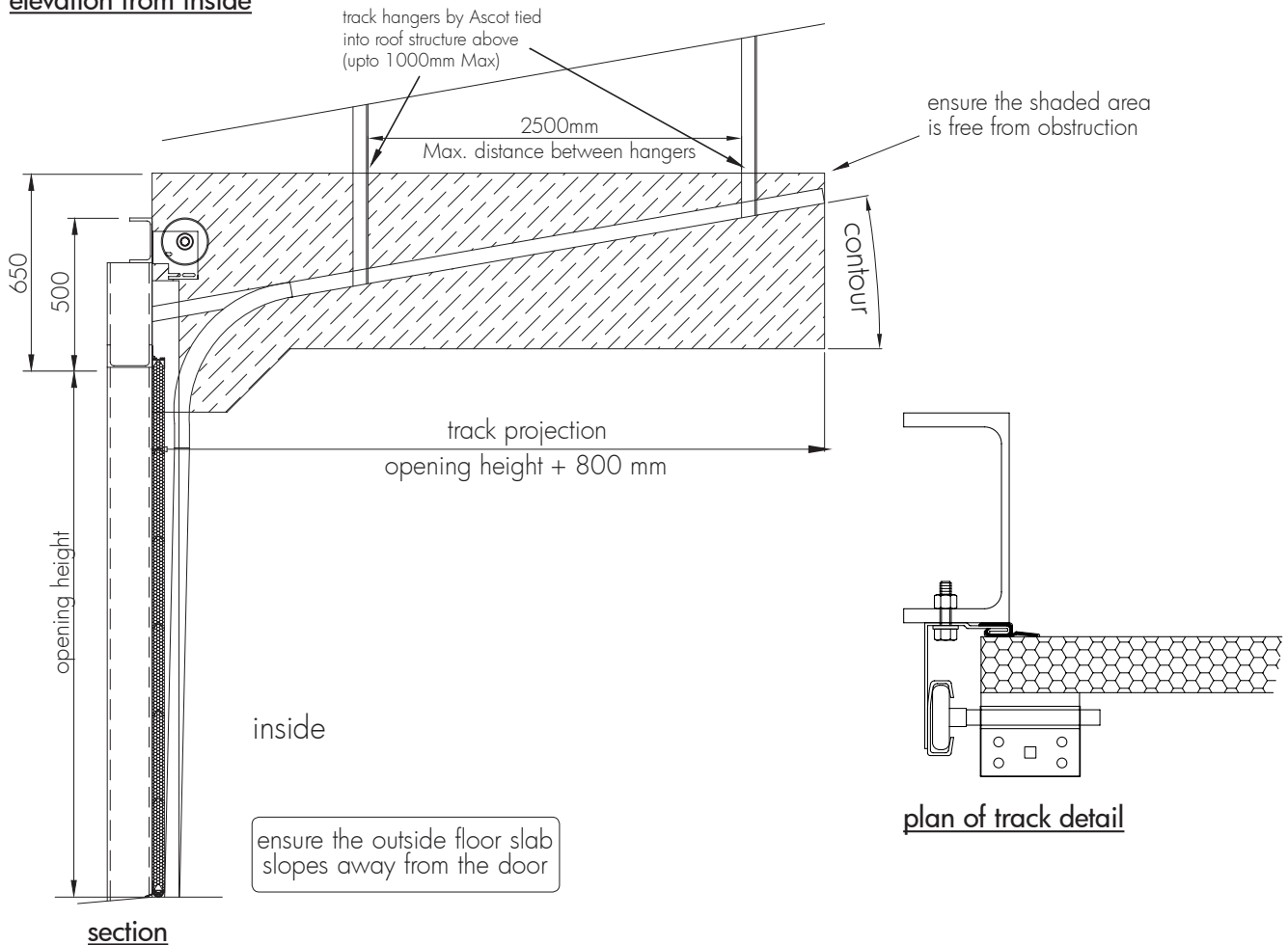

High lift track

High lift track arrangements are used when space above the door allows and where the door needs to clear pipes, crane beams etc. Note, the structure must be capable of carrying a door load of 25 kg/m².

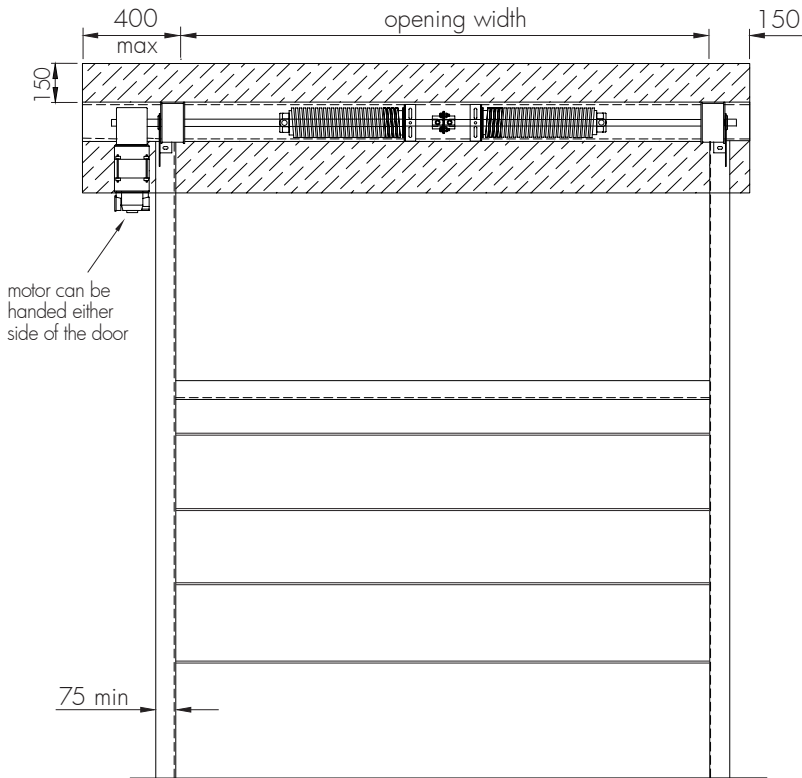

elevation from inside

Track arrangement	max width	max height	Max ² m
-------------------	-----------	------------	--------------------

High lift	7000	6000	36
-----------	------	------	----

Side room requirements	mm	mm
------------------------	----	----

Push-up	150	150
---------	-----	-----

Chain hoist doors	350	150
-------------------	-----	-----

Electrically operated doors	400	150
-----------------------------	-----	-----

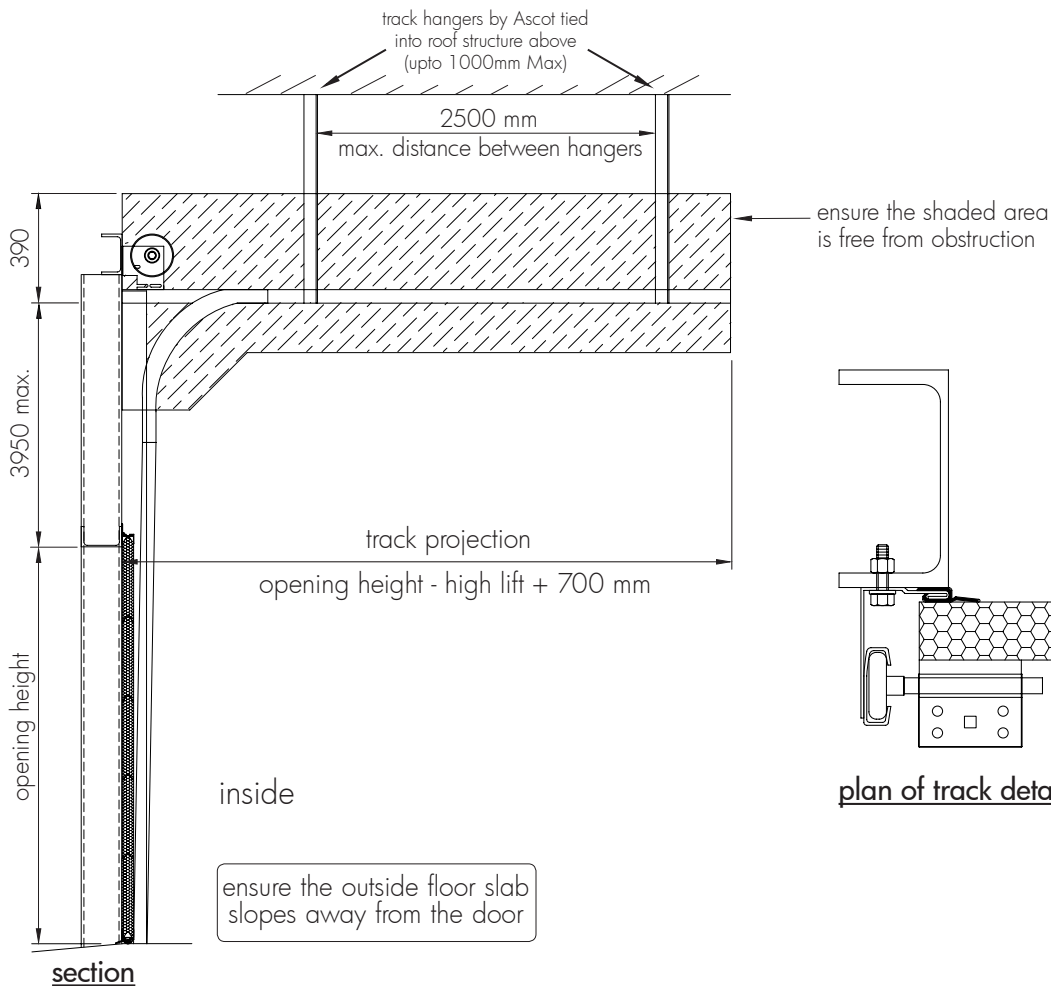

section

plan of track detail

Vertical lift arrangement

Vertical lift track arrangements are used on high bay buildings. This arrangement allows high vehicles to cross along the door opening without obstructions. Note, the structure must be capable of carrying a door load of 25 kg/m².

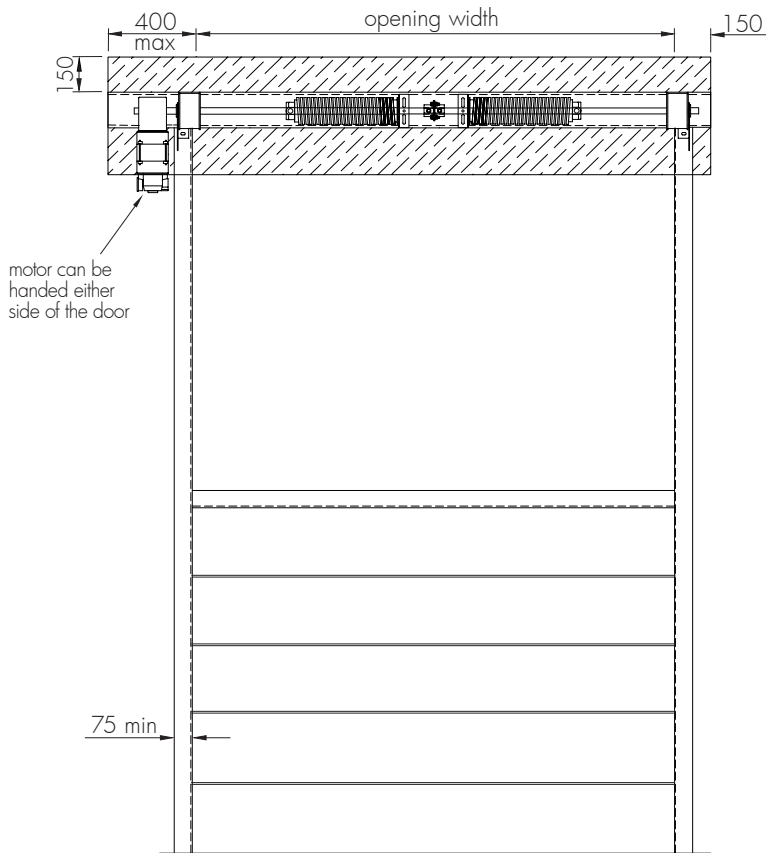

elevation from inside

Track arrangement	max width	max height	Max ² m
-------------------	-----------	------------	--------------------

Vertical	7000	6000	36
----------	------	------	----

Side room requirements	mm	mm
------------------------	----	----

Push-up (up to 300 x 300)	150	150
---------------------------	-----	-----

Chain hoist doors	350	150
-------------------	-----	-----

Electrically operated doors	400	150
-----------------------------	-----	-----

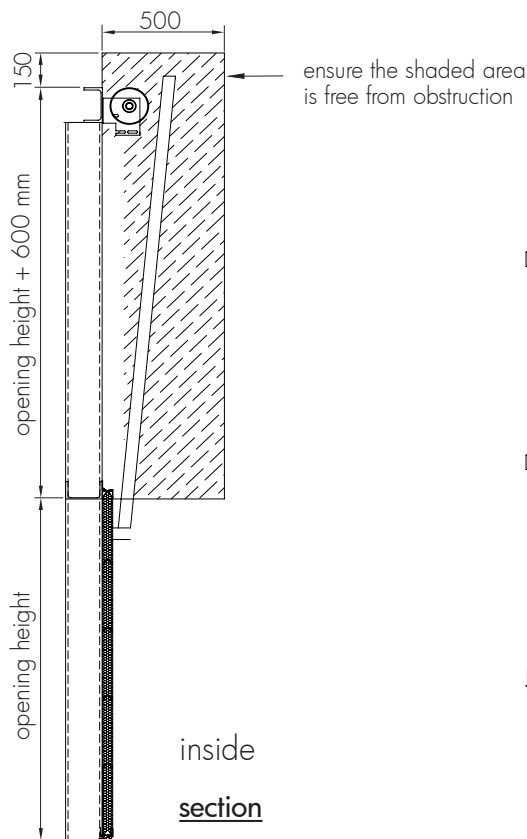

ensure the outside floor slab slopes away from the door

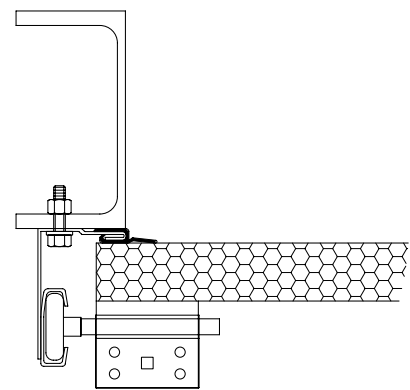

plan of track detail

Low headroom track

Low headroom track arrangements are similar to standard lift but with the spring package at the rear of the door. The headroom can be reduced to a minimum of 220 mm. This allows you to achieve a maximum daylight height with a minimum headroom requirement. Note, the structure must be capable of carrying a door load of 25 kg/m².

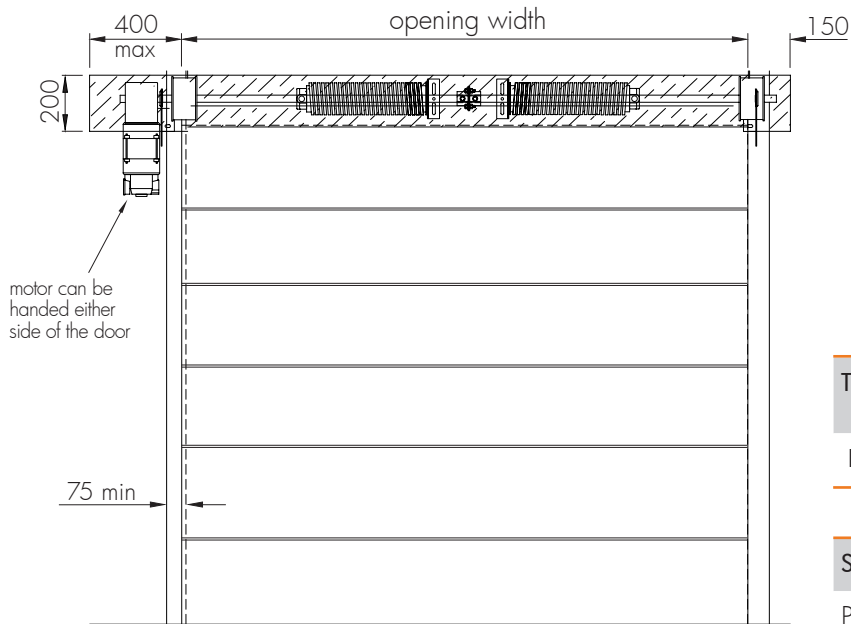

elevation from inside

Track arrangement	max width	max height	Max ² m
Low headroom	5000	4000	16

Side room requirements	mm	mm
Push-up	150	150
Chain hoist doors	350	150
Electrically operated doors	400	150

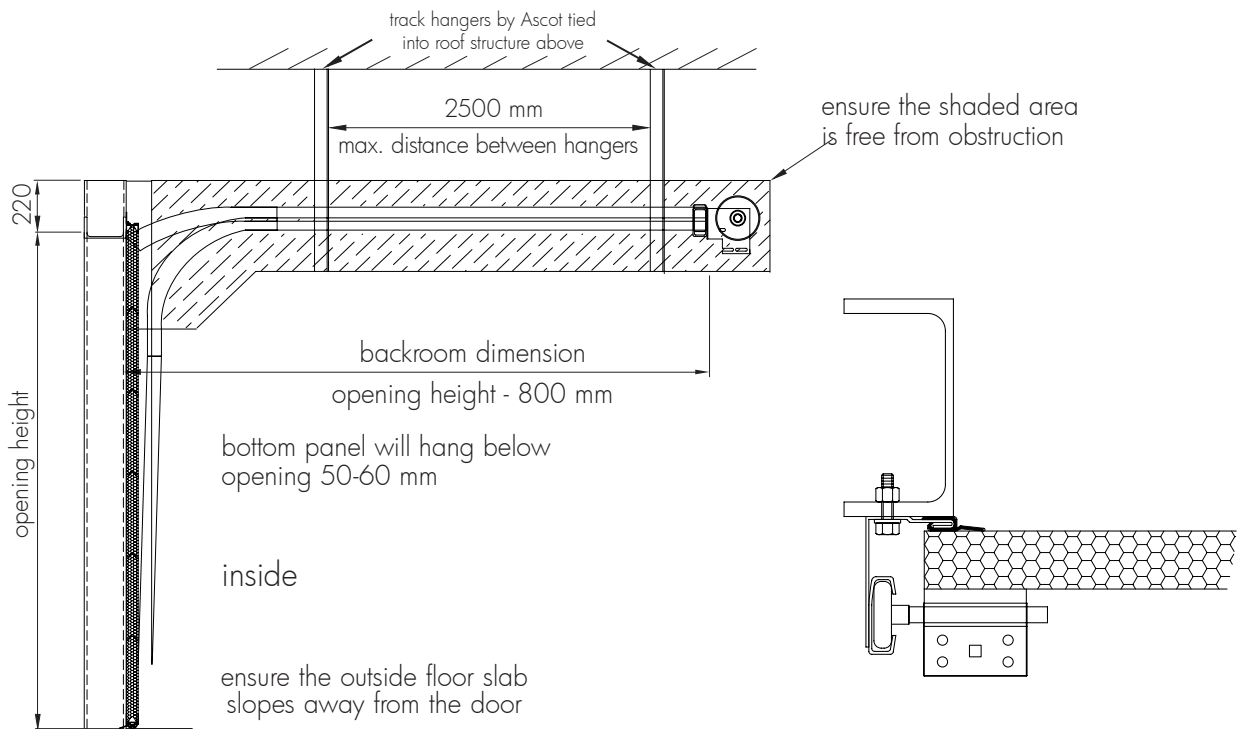

section

plan of track detail

Options

Wicket doors

Where pedestrian access is needed in doors 3050 mm to 5000 mm wide. Wicket doors provide access without raising the whole door reducing the amount of heat lost. Wicket doors are constructed from the same materials as the doors to give good aesthetics whilst maintaining a robust and durable door.

Vision windows

A variety of acrylic double glazed and fully sealed window patterns are available: square, radiused corners, rounded rectangle and round suit most design requirements. Windows are an option on solid panel doors and can be fitted at one per metre width of door to a maximum of five windows.



square corners



radiused corners



rounded rectangle



round

Locking options

Our range of integrated and retro-fittable locking options provide increased levels of security and includes industry leading locks ranging from the standard shootbolt to electrically interlocked systems.

Fully glazed doors

Ascot offers a range of fully glazed or partially glazed doors manufactured from aluminium sections with a variety of panel glazed options.



Wicket door

Colours and finishes

Doors are finished in an Architectural polyester paint stucco embossed finish as standard. An optional Plastisol finish is available in a range of standard colours or a factory applied paint in any RAL or BS colour. The internal face is finished in white (RAL 9010) as standard. For a full range of polyester and plastisol colours please click onto our web site: www.ascotdoors.co.uk.

Operation

Manual operation

Doors can be operated by either manually push-up or for larger doors by using a hand chain mechanism.



Handchain mechanism

Electrical operation

Our range of single and three phase electrical drive units are available in a range of speeds from 22 rpm to 48 rpm and torques up to 140Nm. The hard wearing precision made worm gears ensure a long, maintenance free life. The sealed gearbox allows the unit to be installed either horizontally or vertically according to space limitations.

The motor drives are supplied with directly driven, built-in limit switches to maintain a precise stopping position under all circumstances. The limit switch housing incorporates plug connectors for limits and motor supply, enabling a series of different control packages to be connected.



Spring loaded shootbolt

Standard electrical controls

Control panel

Electrically operated shutters are installed with a TS958 control panel as standard. The control panel is supplied with a pluggable cable for connecting to the motor, a 3 pin red CEE plug on a 0.5M lead for connection to the power supply and allow the door limits to be programmed from floor level.

The TS958 control panel can be programmed to allow the door to 'impulse' open and has a service counter, life time cycle counter and fault diagnosis. Special electrical controls are available on request.



Electrical options

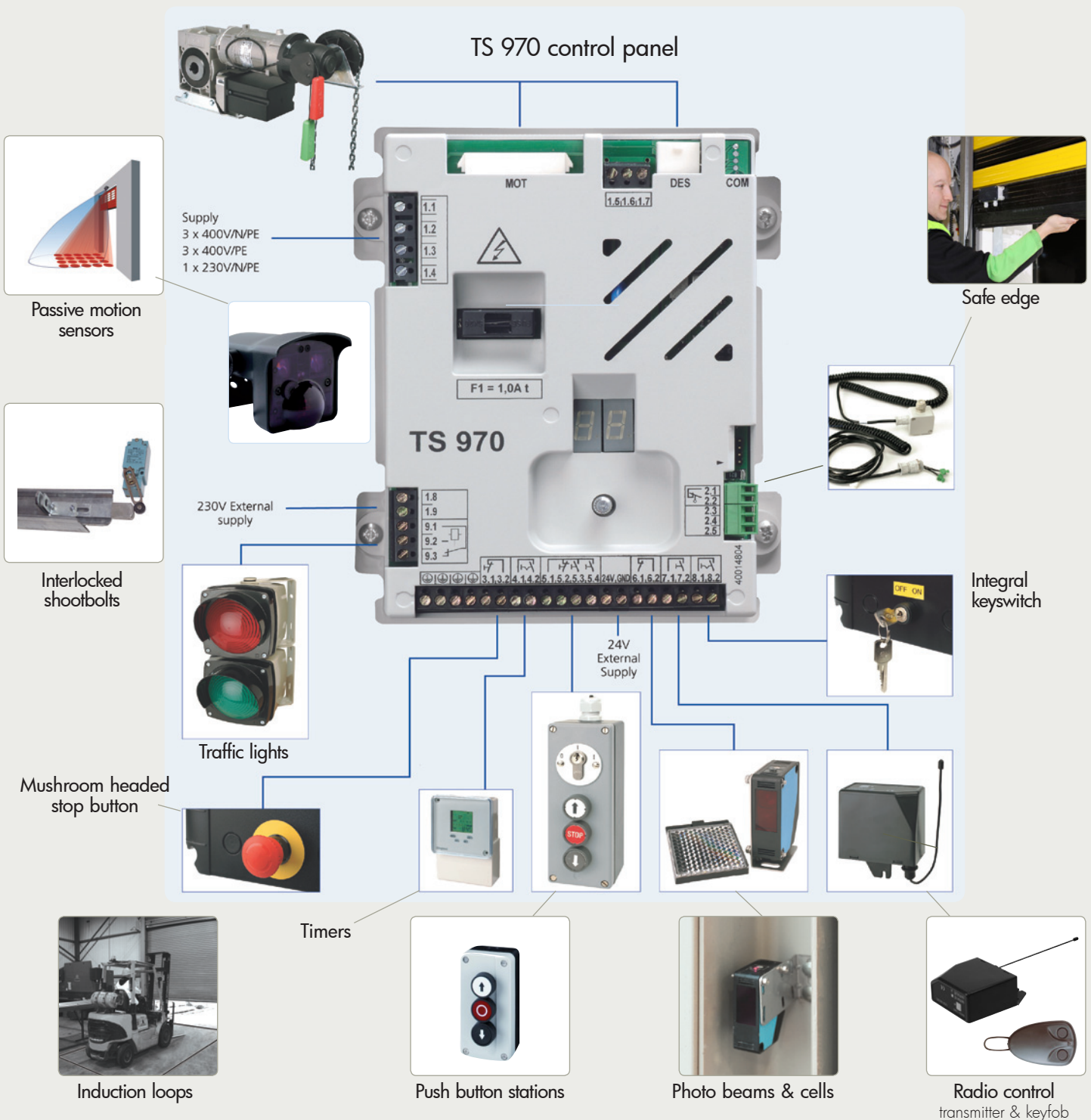

Ascot Service and Repair

Fast and reliable for peace of mind. To ensure your doors are maintained in good working order, our UK-wide network of Service Centres are strategically placed to provide the fastest possible response time. If you have a breakdown our stocked service vans can be at your site fixing your door, FAST!

Service

Our nationwide service centre network attend scheduled maintenance visits and on-site repairs. Emergency repairs are often attended within 4 hours. With over 25 years experience manufacturing, installing and repairing doors and 11 service centres, Ascot is the ideal partner you can rely on to maintain your industrial, commercial and retail doors.

Repairs

Damaged doors cause downtime to operations, whether it's people traffic or moving goods in and out of buildings. Business today is moving faster, damage and malfunctions must be repaired quickly and professionally by trained technicians. Whether it's one of our doors or another make, Ascot Service and Repair can fix it.

Maintenance agreements

A maintenance agreement offers regular service levels to make sure the frequency of door usage is maintained and to diagnose problems before failure and disturbance to traffic flows occur. Planned regular maintenance increases functionality and reduces expensive downtime.

Upgrades and replacements

In time, your door requirements will change. Improvements in operations and technology will place greater demands on movements in and out of buildings. Whether it's moving or resizing doors, changing or adding safety and security features, the Ascot Service and Repair team can handle it.

Spare parts

A comprehensive spare parts distribution network, together with well stocked service vans means we get engineers and parts to your site within 24 hours of ordering.



contact service:
01204 309 908
service@ascotdoors.co.uk



Construction Skills Certification Scheme

CSCS was set up to help the construction industry to improve quality and reduce accidents. Ascot service and repair technicians hold CSCS cards which are increasingly demanded as proof of occupational competence by contractors, public and private clients and others.



LPS1197
Certificate No. 131c

new door enquires
01204 545 801

24/7 service hotline
01204 309 908

service centres

North East

Unit 1 C, Dean & Chapter Industrial Estate
Ferryhill, COUNTY DURHAM DL17 8LN
Tel: 01740 657 171
Fax: 01740 657 931

North West

Unit 1, Viola Street, Astley Bridge
BOLTON BL1 8NG
Tel: 01204 309 908
Fax: 01204 300 532

West Midlands

Unit 18, (D), Wednesbury Trading Estate,
Wednesbury, BIRMINGHAM WS10 7JN
Tel: 0121 502 5934
Fax: 0121 502 5931

South Central

Unit 2, Lennox Industrial Mall, Lennox Road,
BASINGSTOKE RG22 4DF
Tel: 01256 322 566
Fax: 01256 353 002

South West

Unit 21, Blake Mill Business Park,
Brue Avenue, BRIDGWATER TA6 5LT
Tel: 01278 439 313
Fax: 01278 439 200

Scotland

Unit 59, Evans Business Centre, Bellshill Ind. Est.
BELLSHILL, Lanarkshire ML4 3NP
Tel: 01698 574 540
Fax: 01698 748 625

Yorkshire

Unit 20, Grange Lane Industrial Estate
Stairfoot, BARNSELY S71 5AS
Tel: 01226 246 667
Fax: 01226 248 271

Midlands

Unit 7 Oaks Industrial Estate,
Coalville, LEICESTER LE67 3NQ
Tel: 01530 817 682
Fax: 01530 817 680

East Anglia

Unit G3, Seedbed Centre, Wyncolls Road
COLCHESTER CO4 9HT
Tel: 01206 843 413
Fax: 01206 843 319

London

Unit L, The Business Centre, Faringdon
Avenue
Harold Hill, ROMFORD RM3 8EN
Tel: 01708 386 900
Fax: 01708 386 886

South East

Unit 36, Thomas Way, Lakesview Business Park
Hersdon, CANTERBURY CT3 4JZ
Tel: 01227 711 757
Fax: 01227 713 786



head office

Ascot Doors Limited
Britannia Way Industrial Park
Union Road, Bolton BL2 2HE
Tel: 01204 545 801
Fax: 01204 545 800

www.ascotdoors.co.uk
sales@ascotdoors.co.uk

